



Researches on Marine Finfish and Shrimp Farming

by

Pinij Kungvankij

Regional Lead Centre in the Philippines
Network of Aquaculture Centres in Asia

NETWORK OF AQUACULTURE CENTRES IN ASIA
Bangkok, Thailand
November 1985

Researches on Marine Finfish and Shrimp Farming

1. INTRODUCTION

The Aquaculture Department of the Southeast Asian Fisheries Development Center (SEAFDEC) is one of the four regional lead centres participating in the regional activities of the Network of Aquaculture Centres in Asia (NACA) to carry out regional research, training and information activities. In formulating the research activities for the Regional Lead Centre in the Philippines (RLCP), FAO has assigned a task force to prepare viable research programme in consultation with the research leaders of the Centre. The task force also held a number of consultation with some of the leading fish pond operators, officers of the government and University. The programmes for the Regional Aquaculture Lead Centres in Asia is contained in the document ADCP/REF/80/14 (En.).

The farming system selected for the Regional Lead Centre in the Philippines are (i) shrimp culture in ponds and (ii) pond culture of milkfish, mullet and other brackishwater finfish. However, because of limitation of funds, facilities and

technical manpower, research will be concentrated on priority commodities of the country which also are of regional interest.

While noting the effort of IDRC in establishing breeding and culture technology for milkfish, the Centre focuses its initial attention and effort on the farming of shrimp in brackishwater ponds and culture of other brackishwater finfish (seabass and grouper). The selection of shrimp is due to its high market value and its economic importance to the shrimp cultivated in the various tropical and sub-tropical Asian countries. The rapid decline of supply from the wild has led many countries to launch massive programmes to culture the species which has a lucrative export value. However, appropriate farming technology has not been fully developed resulting to frequent shortage of feed supply, poor harvest and in some cases collapse of production farms.

Seabass and grouper are commercially important fish species in countries of the tropical and sub-tropical areas of the western Pacific and Indian oceans. Seabass and grouper culture in ponds and cages have been practiced in the Southeast Asian region and have been considered as having high potential for aquafarming in tropical Asia-Pacific region. The limitation of seabass and grouper farming is in the dependency of the industry on the natural fry stocks from the wild. The successful spawning of these species in captivity have stimulated wide interest. However, these are carnivorous species and would require suitable feeds such as trash fish or compound feed for their cultivation. Moreover, the techniques on seed production and grow-out farming in ponds and cages as well as the availability of economic analysis are yet to be refined to reduce existing production cost.

The development of the aquafarming industry can only be accelerated based on appropriate production technologies. The major research approach of the lead centre is therefore to concentrate its research effort in the filling up of technological gaps of the culture technology of shrimps and finfish as well as the verification and testing of technology generated before application by fish growers in the region. The Center adopts production oriented, interdisciplinary research approach with the intention of generating appropriate technologies within the shortest possible time (Fig.1).

Since the establishment of the center in late October 1980, the initial phase was concentrated on the recruitment of international research staff, establishment of infrastructure and procurement of equipment while some research work had begun simultaneously with infrastructure development. Full scale research activities were not undertaken until the beginning of 1983.

2. OBJECTIVE

- To organize and implement multi-disciplinary research on selected aquaculture system, with special reference to marine finfish and shrimp culture system
- The technologies developed through the research work in the centre will be packaged and transferred through testing and adoption to suitable local condition.

3. PROGRAMME IMPLEMENTATION

3.1 Selection of project site for shrimp/finfish research

While the Project Office is located at the main station of the SEAFDEC AQD in Tigbauan, suitable site has to be selected for the conduct of production-oriented experiments. Considerable efforts have been made by the project and the Department in selecting a suitable site all over Panay Island. Upon the recommendation of the exploratory team, Leganes Research Station of the Department was selected as the site of the inter-disciplinary research of RLCP due to the following reasons:

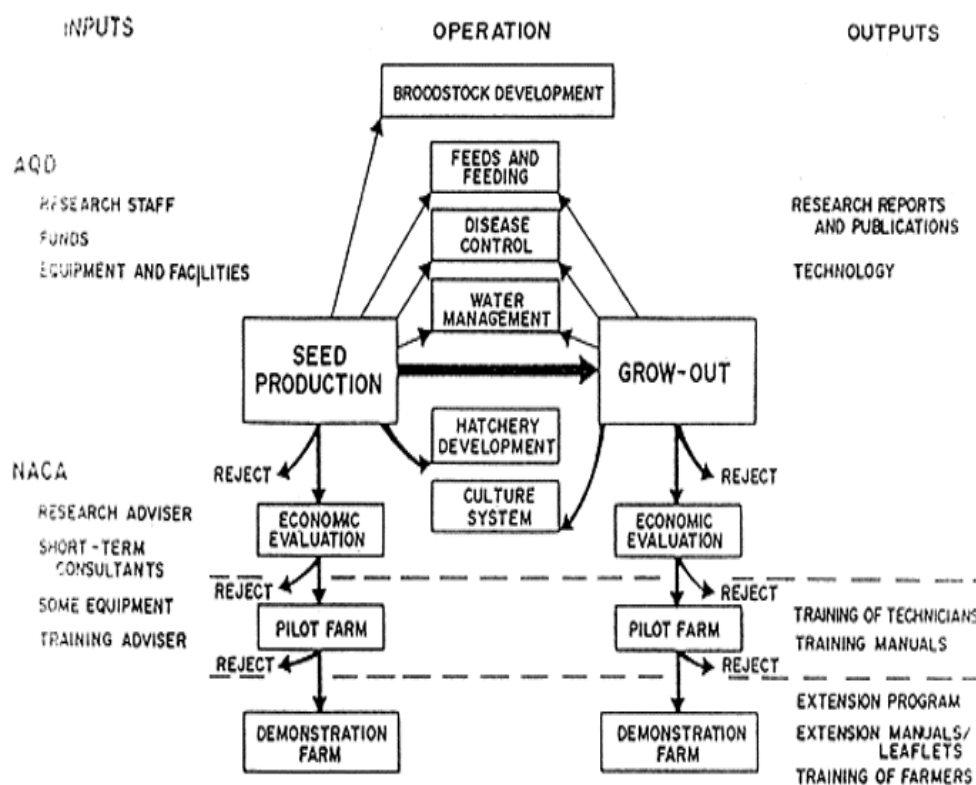

FIG. 1. RESEARCH APPROACH OF THE PHILIPPINE LEAD CENTRE OF NACA IN TECHNOLOGY GENERATION AND VERIFICATIONS OF SHRIMPS AND FINFISH FARMING.

- It is technically suitable although there exist some technical problems in salinity regulation which could be overcome.
- It is accessible and has sufficient facilities to meet the basic needs of researchers and staff working there.
- There are available land area for construction of hatchery and grow-out facilities.

3.2 Development of research infrastructure and facilities

With the support of the Department administration, the necessary infrastructure facilities were developed and the administration of the Leganes Station reorganized to provide the necessary supportive services needed for effective implementation of the research programme.

The Department has provided initial financial support in the construction of pond facilities and portion of the hatchery-nursery complex. FAO/UNDP contribution are largely equipment, part of the construction cost of hatchery-nursery complex (Table 1), consultants and international staff for the project.

3.2.1 Facilities

- a. Ponds - The Department has allocated a three hectare land in Leganes Research Station for the construction of experimental ponds. The ponds were designed by the NACA consultants and construction began on February 1982 and completed on July 1982. The pond system consists of twenty 320-m² ponds and twelve 620-m² ponds each equipped with independent inlet and outlet pipes directly connected to the supply and drainage canals. The ponds can be tidal fed. Only half of the smaller ponds and all the bigger ponds are provided with feeding platforms (Fig. 2, 3 and 4).
- b. Broodstock-hatchery-nursery complex - The complex consist of ten 200-liter spawning tanks, four 12-ton broodstock circular tanks, twelve 2.5-ton larval rearing tanks and ten 40-ton nursery tanks (Fig. 5-9). The other life support facilities include two sets of 10 Hp marine pumps, two 10-Hp root blowers, thirty 1-ton fiberglass tanks for mass culture of live food organisms and a small phycology laboratory for maintaining pure culture of diatoms. The construction of the USD 0,000 complex began on August 1982 and was completed by mid-December 1982. In the meantime, the Department has also initiated construction of living quarters near the complex which can be utilized to house research/technical staff of the programme.
- c. Water supply system - The water supply system of the Leganes Research Station was also improved with the installation of push pumps contributed by NACA. The push pumps were installed with the purpose of lowering extremely high salinity in the ponds in summer months by pumping seawater into the supply canal. The installation was completed in February 1983.
- d. Research equipment - Most of the laboratory and research equipment needed by the research projects are contributed by UNDP/FAO through NACA. However, available equipment in the Department are also being used for the implementation of the research programmes.

<u>Input</u>	<u>NACA</u>	<u>SEAFDEC</u> <u>AQD</u>
International staff	in kind	
Salary of counterpart staff		in kind

Construction of ponds		35,000
Construction of hatchery-nursery complex	30,000	66,000
Equipment	41,250	30,000
Operational Cost	<u>15,000</u>	<u>95,100</u>
Total	US\$ 86,250	226,100

Table 1 - Contributions from FAO and SEAFDEC AQD in the establishment of infrastructure and operation of the RLCP Research Programme 1982-84.

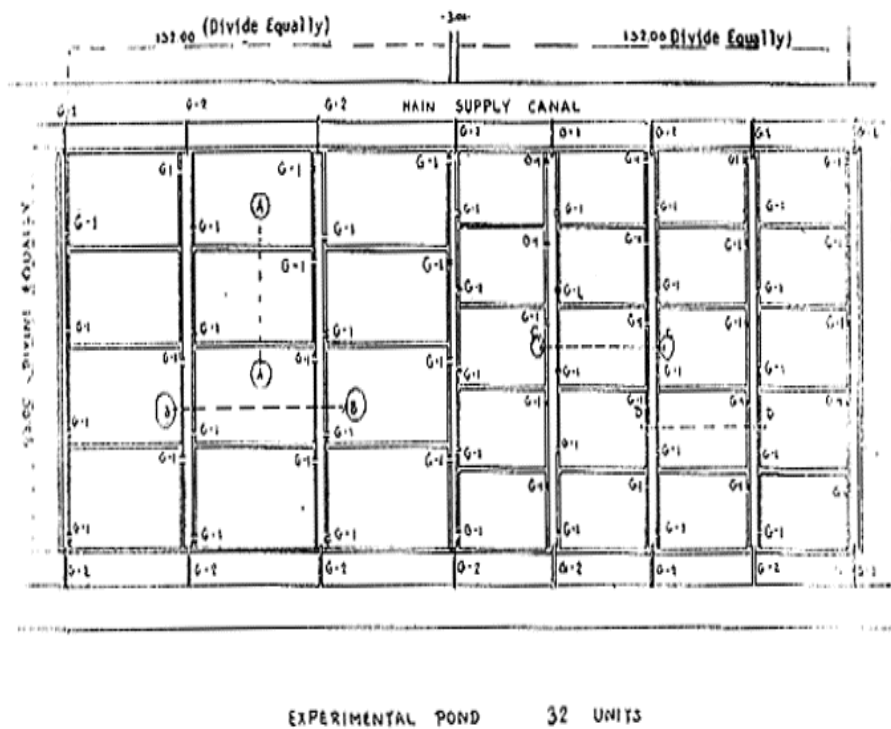

Fig. 2 - Lay-out of experimental ponds at Leganes Research Station

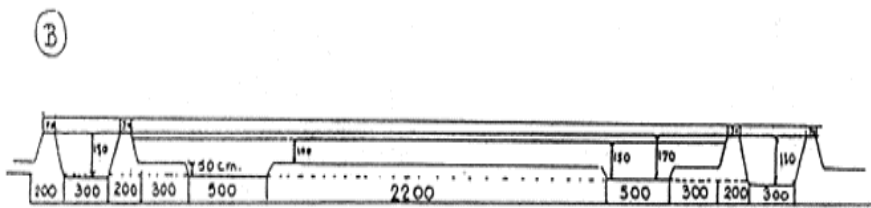
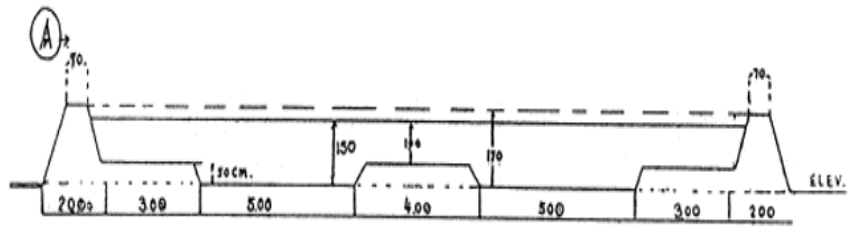

Fig. 3- Cross Section of Pond

- A. Det. Sect. thru A-A
- B. Det. Sect. through B-B

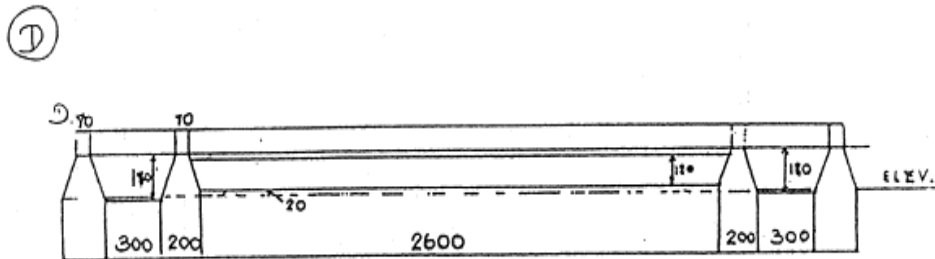
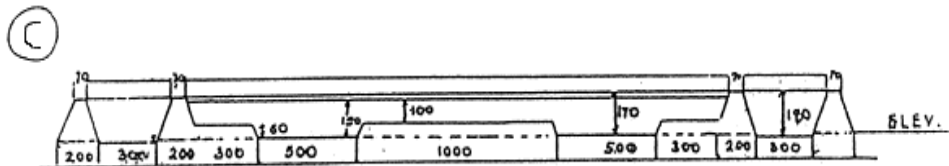

Fig. 4 - Cross Section of Pond

C. Det. Sect.
thru C - C

D. Det. Sect.
thru D-D

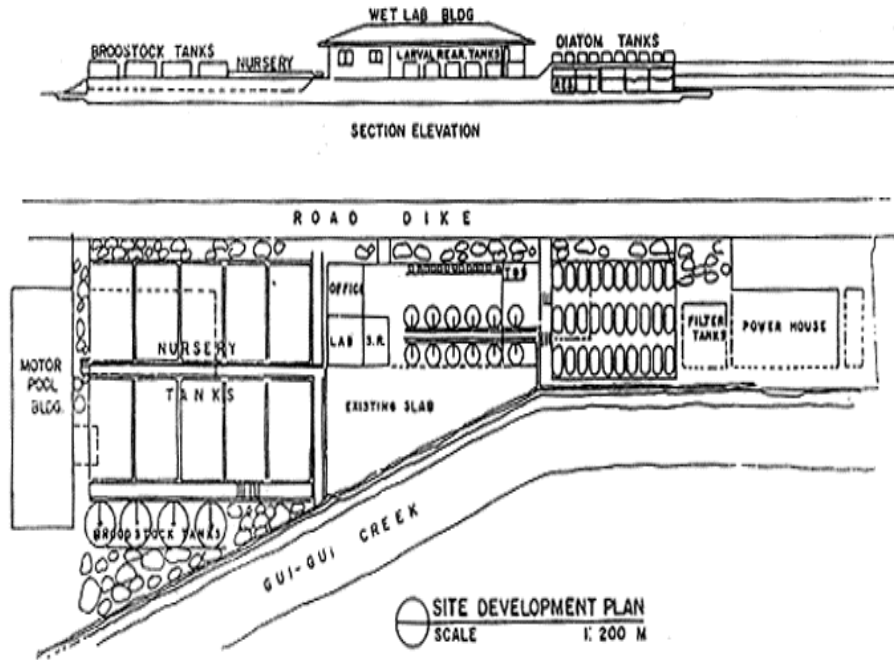

FIG. 5. LAYOUT OF MEDIUM SCALE HATCHERY

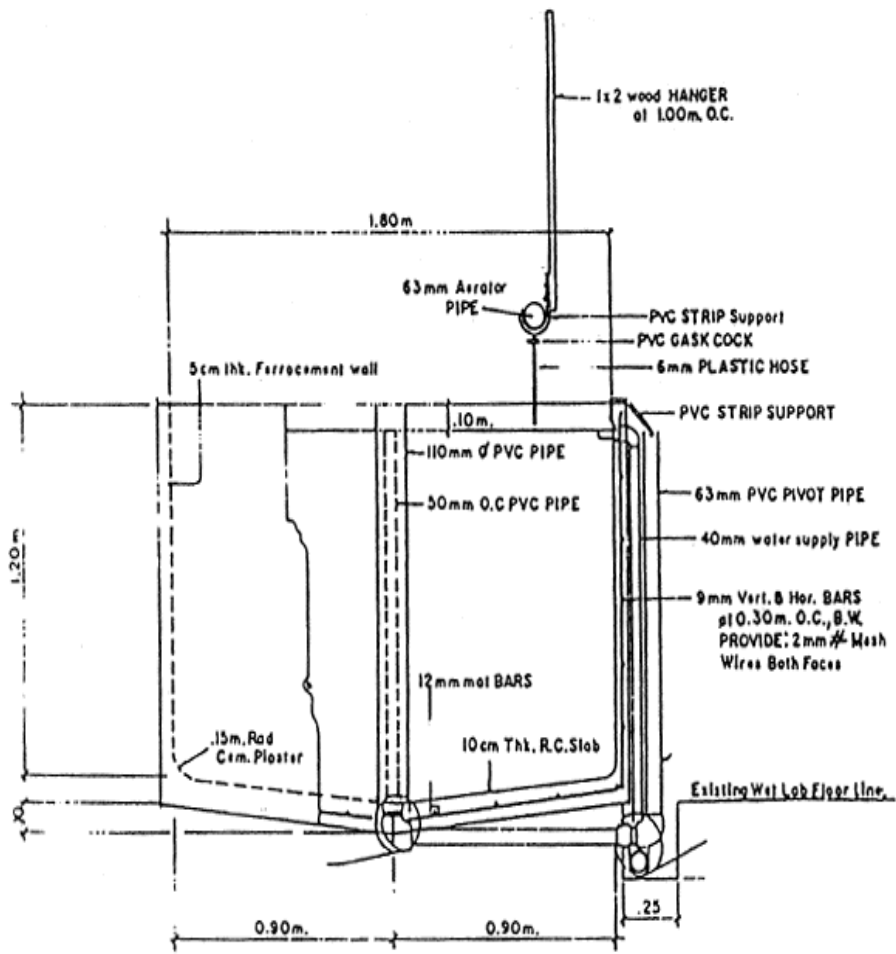

Fig. 6 Cross-sectional detail of 2.5 tons ferrocement larval rearing tank

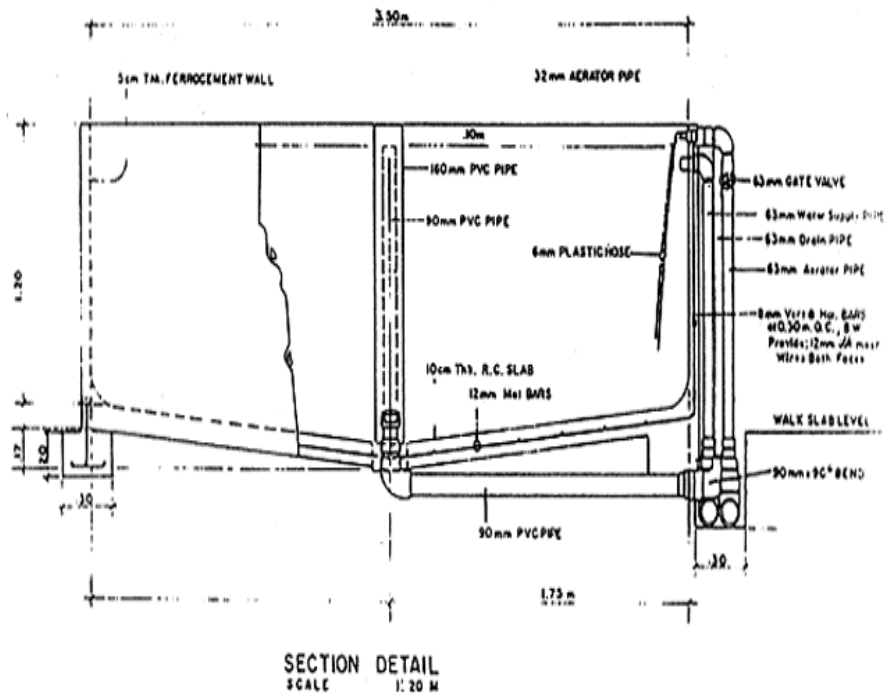

Fig. 7 Cross-sectional detail of the 12 tons ferrocement Broodstock tank

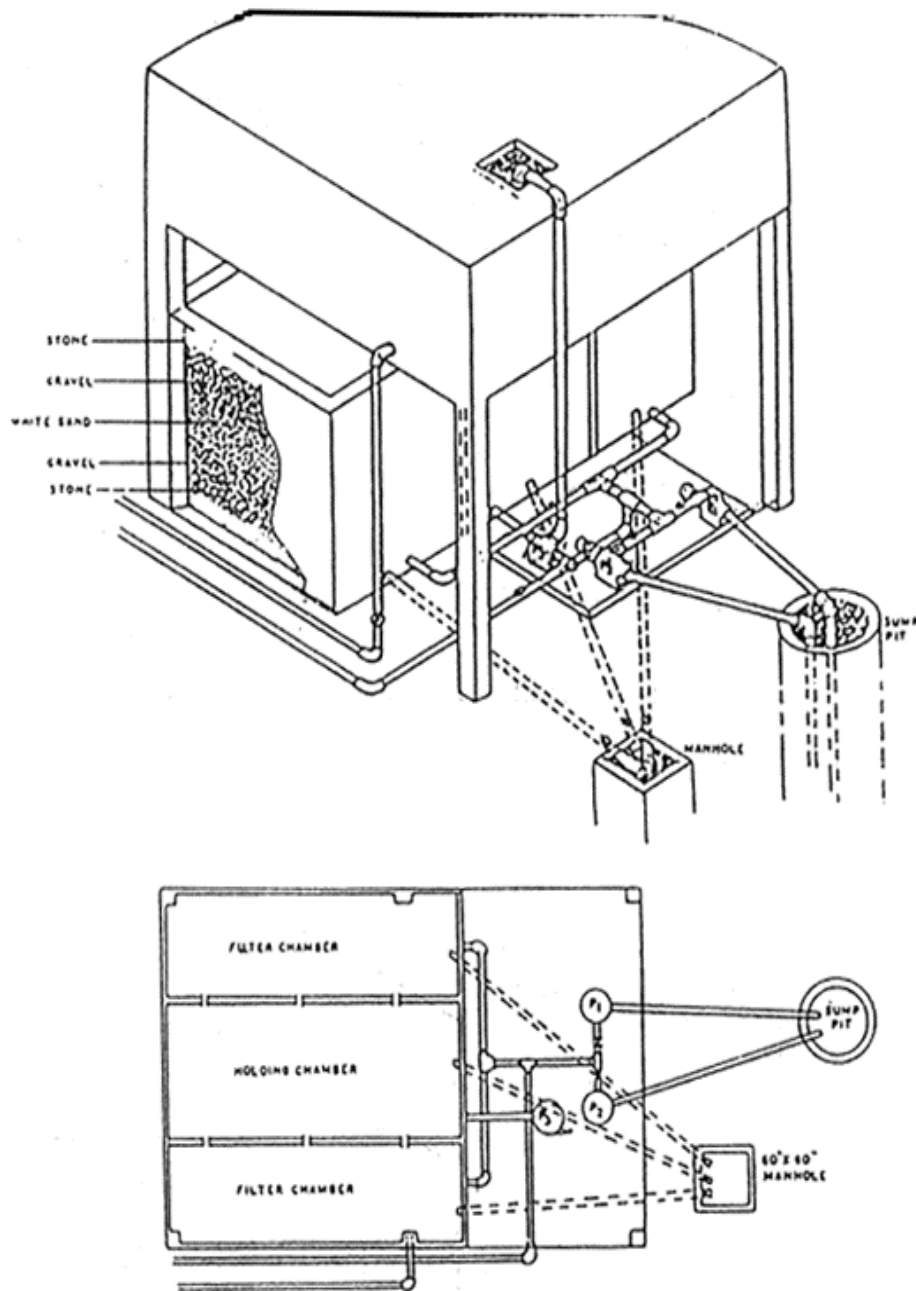

Fig. 9. Water storage and filtration tank

3.2.2 Research personnel

While the research approach is inter-disciplinary, the research team of RLCP is made up of various specialists in broodstock development, hatchery and nursery management, culture of live food organisms and pond management. The team is headed by a team leader who is the international research staff and a co-team leader who is the local counterpart. The present team consists

of 8 scientists, 2 technicians and 5 workers. Due to the serious economic constraints of the Department, the full compliment of the research team of 30 staff cannot be realized. With the change of management of the Department on January 1982, the research team is made up of the following:

Team Leader : Piniy Kungvankij (FAO)

Scientists : L.B. Tiro, Jr., Research Associate (SEAFDEC AQD)
B.J. Pudadera, Research Associate (SEAFDEC AQD)
K.G. Corre, Research Associate (SEAFDEC AQD)
I.O. Potestas, Sr. Research Assistant (SEAFDEC AQD)
E. Borlongan, Sr. Research Assistant (SEAFDEC AQD)
G.A. Taleon, Research Assistant (SEAFDEC AQD)
A. Unggi, Sr. Research Assistant, SEAFDEC AQD)
L.F. Gustilo, Sr. Research Assistant (SEAFDEC AQD)

3.3 Research in shrimp farming

The research programmes were formulated after a critical review of the shrimp farming industry and the research needs clearly identified.

3.3.1 Background and research needs

The traditional brackishwater pond culture of shrimp is widely practiced in Asia. In many countries, production is still highly dependent on the seasonal abundance of the wild fry. In many cases, the ponds are very shallow and water temperature and salinity becomes so high that large scale mortality occurs. Predation by extraneous fish that gain access to the ponds also accounts for considerable loss of shrimps. Fertilizers and feed are not generally used and as there are no suitable feeds available, production depends almost entirely on natural fertility. Consequently, yields are low, generally in the range of 100 to 300 kg/ha/year.

Some improvements in the traditional method of culturing shrimps have been evolved. For instance, by using push pumps or dragon wheel pump, more shrimp larvae could be concentrated as a result of increasing water intake or by providing increased water depth in the pond favourable temperatures can be maintained and mortality reduced. Production can be raised by increasing stocking density in ponds with fry collected from the wild. It has demonstrated that nursery rearing of post larvae before stocking them in grow-out ponds help to increase survival rate. This will undoubtedly result in increased yields, but production will still remain relatively low until research provides solution to other more complex problems which limit production.

One of the most critical aspects in shrimp farming is the availability of post larval shrimp for stocking. It is generally very difficult to find a dependable source of post larvae for large scale operations. When there is a scarcity of fry,

as in the case of the tiger shrimp, Penaeus monodon, the price becomes very high. When the fry are expensive, they are stocked at low densities and grown to large sizes. This increases risk considerably. If cheap fry were available it would be possible to stock ponds at higher densities and harvest at a smaller size after a shorter growing period. Of course the relative economic advantage of one system over the other must be considered, but at the present time, there is no option due to lack of fry.

Considerable research has been done for developing shrimp hatcheries within the region, but procedures for commercial scale hatchery operations are not yet fully developed. Present hatchery methodology utilizes live foods and as there are many problems concerned with their use, it will be advantageous to develop artificial feeds for use in the hatchery. In recent years, progress has been made in maturing broodstock in captivity through the use of eyestalk ablation, but the percentage of females attaining maturity are always fluctuating and the number of viable eggs obtained from them are still low.

Traditional shrimp culture is based on the number of species and even in improved systems, there are maybe benefits in using more than one species. For example, even though P. monodon is generally considered to be the best species for culture in the region, it may not be the most suitable species to grow in all locations at all times of the year. There are indications that in high salinity ponds, P. indicus might provide a higher return and Metapenaeus ensis might be more suitable for low salinity ponds. Other factors to consider are that the maturation in captivity is easier for some species than the others and that susceptibility to diseases varies greatly from one species to another. Analysis must be made of the various trade-offs possible to evolve the most economical systems.

It is generally recognized that yield can increase by increasing the natural productivity of ponds to supply sincreased amounts of food. There is sufficient information on how to promote growth of the benthic blue-green algae in shallow ponds. Unfortunately, the shallow type of pond is not suitable for growing shrimp because of the high temperature of the pond water. Experimental work done so far has not led to reliable means of increasing the productivity of plankton in deeper brackishwater ponds. Such basic information as the proper ration of nitrogen to phosphorous and dose frequency of application remains to be determined.

Direct feeding is another way of increasing the yield. However, adequate knowledge of the nutrient requirements of the vatioous species of shrimp necessary for formulating efficiently has yet to be obtained. Feeding, to date, is based almost entirely on natural productivity or surplus products such as trash fish. These feed stuffs are not very efficient and if used in high quantities, tend to cause management problems by fouling the water.

In traditional forms of shrimp culture, very few disease problems have been recognized. However, with the adoption of intensive culture methods, diseases become a major problem especially in hatchery operations. Shrimps seem to be subject for infection by a viral infection. In many cases, catastrophic

mortalities occur. One very common occurrence reported in the region for which no causative factor has been identified is persistent soft shell condition of shrimp grown in ponds.

3.3.2 Research approach

Most of the shrimp culture researchers in the region has concentrated on Penaeus monodon, the spawners of which remain as one of the major constraints in the development of prawn culture industry today. There are many reports on maturation due to eyestalk ablation which hopefully will be commercially feasible in future days. But so far, successful cases are very few. The age of broodstock, reproductive physiology and selection of females are major aspects that should receive attention and effort to improve the percentage of individuals that respond to the eyestalk ablation technique. Broodstock from the wild and those culture in ponds in different age groups, fed with different live and compounded feeds, might be studied to determine the quality and quantity of eggs, hatching rate and quality of larvae. The possibility of maturation in ponds and in net cages installed in ponds should be tested and comparison made with maturation and spawning in tanks.

The effect of water quality on maturation, hatchery and larval survival as observed in typical hatchery sites will have to be evaluated to develop reliable criteria for selecting hatchery sites. Refinement of the culture techniques on mass culture of larval feed such as phytoplankton, zooplankton and marine yeast to ensure a consistent supply and the efficiency of artificial feeds should be evaluated not only in terms of growth, condition and survival of larvae, but also in terms of economics and convenience of operation. Through appropriate experiments, the effect of different variables such as stocking density, feed and feeding which include preference, size, quality and feeding frequency as well as management should be evaluated. The conditions under which infections such as that caused by fungus (Lagenidium sp.), bacteria and protozoa become an epidemic, should be determined and suitably controlled.

For the improvement of nursery system, comparative tests of different tanks and raceways designs will be needed. Efforts may be made to increase the optimum stocking density of post larvae by providing additional substrates. Improvement of traditional earthen ponds, nursery system with special reference to production and maintenance of food supply, water management and control or elimination of pests, predators and competitors should be studied.

In studies aimed at the improvement of grow-out systems, optimal stocking density in various types of culture systems viz: extensive, semi-intensive, and intensive culture, pest and predator control, disease prevention as well as water management should be studied. Pond water with fertilization and only supplementary feeding should be compared and evaluated. The technical and economical advantages and disadvantages of polyculture of shrimp with milkfish or other finfish, alternate production of P. monodon/P. indicus at low and high salinity and partial harvest should be tested.

The economics in the production of seeds and the adult shrimps also need to be verified before pilot and demonstration farms can be established. Besides these, genetic studies could play a major role in improving shrimp culture, but it is essential to determine in advance the objectives of genetic manipulation and the characteristics that need to be studied such as earlier maturation, growth rate, food conversion and resistance to disease for obtaining useful results.

3.3.3 Research studies in shrimp farming

3.3.3.1 Broodstock

Insufficient and inconsistent supply of spawners of tiger shrimp has become the bottleneck for large-scale commercial development. The need to reduce dependency on wild spawners becomes a major challenge to researchers. The present research studies therefore, attempts to produce pond reared broodstock and verify the various techniques that have been developed to induce gonadal maturation.

(a) Culture of marketable size tiger shrimp (P. monodon) to broodstock size in brackishwater ponds

The main purpose of this study is to develop an appropriate technique to produce a pond reared broodstock supplied consistently to the hatchery. The experiment was conducted in a nine 300-sq.m. earthen pond with marketable size shrimp (average weight is 30 g) stocking at 1 per sq.m. Prior to stocking, the ponds were prepared by eliminating the predators and competitors before application of lime. Different types of supplementary feeds viz: commercial shrimp pellet, trash fish and combination of pellet and trash fish are given at 3% of estimated total biomass. Each treatment was allocated at completely randomize design with three replications. The result after a culture period of 6 months resulted to average weight of 92 g, 86 g and 56 g broodstock with a survival rate pf 48%, 38% and 22% under the treatment of pellet, combination of pellet and trash fish and trash fish respectively.

The result of this experiment showed that after a culture period of 6 months (10 months from PL₂₀), the shrimp attained the broodstock size with an average weight of 80-100 g. The shrimp at this size is suitable for gonadal maturation. However, the mortality rate is very high. Culture period is long. Further studies are necessary to emphasize more on nutritional aspect which might give better results on growth rate, survival rate and quality of broodstock.

(b) Testing and refinement of maturation techniques

- i. Inducing the maturation of tiger shrimp in pond condition (net cages installed in ponds)

This experiment was conducted to verify whether pond conditions are conducive to induced gonadal maturation. Both ablated and unablated

broodstocks were reared in 18 m³ cages (3 × 3 × 2m) installed in ponds. The stocks in the cages were fed with shrimp pellet (35% protein content). The results indicated that 60% of ablated and 10% of unablated shrimps attained maturity. However, hatching rates were low and the nauplii produced were weak

- ii. Comparison of selected and non-selected broodstock on induced gonadal maturation by eyestalk ablation

Inconsistent spawning rate, low hatchability and weak nauplii have been a common phenomenon in induced maturation of tiger shrimp. Incomplete appendages and broken backs often resulted in low fecundity and low hatchability. Fertilization rate might be affected in broodstock with insufficient spermatophores. Experiments were therefore conducted to verify the rate of maturation of broodstock selected for induced maturation versus unselected stocks in concrete maturation tanks. The criteria for selection are the following:

- complete appendages
- no broken backs
- thylecum full of spermatophore
- body weight exceeds 100 grams

Research results have shown that broodstocks which are properly selected based on the above criteria have higher maturation rate, higher fertilization and hatching rates (Table 2).

- iii. Comparison of maturation rate of pond reared and wild broodstocks

The performance of pond reared broodstock were compared with those obtained from the wild in terms of rate of maturation, hatching rate, spawning rate and quality of larvae. Despite high protein feeds used, wild broodstocks are still superior in terms of rate of maturation, larval quality and economic viability (Table 3).

- iv. Comparison of maturation, spawning and hatching rate of ablated selected wild broodstocks fed with squid and oyster

Selected wild broodstocks were ablated and fed with squid and oyster at 5% total body weight twice daily. Results showed that broodstocks fed with oyster gave better results in terms of maturation, spawning and hatching rate (Table 4). In addition, the production of nauplii per broodstock was also higher.

3.3.3.2 Hatchery and nursery

(a) Verification of shrimp larval rearing techniques

Various shrimp hatcheries have been operating in the region in an attempt to provide the shrimp growing industry the needed shrimp fry. Existing hatcheries

are in various sizes and different level of operations. However, many hatcheries have suffered from erratic production and all are experiencing difficulties in maintaining a constant supply of seeds to the shrimp growers. Basically there are two hatchery systems being adopted. The large tank hatchery which originally developed in Japan is still the popular system applied in many countries in the region (Taiwan, Thailand, Philippines, etc. The small tank hatchery which originates from Galveston, Texas, USA has been applied in the Philippines and to some extent in Malaysia and Thailand. Despite the long period of hatchery development in these countries, many of the rearing techniques are yet to be standardized or refined.

TREATMENT	FEED	NO. OF RUN	TOTAL STOCK			SPAWNERS			TOTAL NO. OF EGGS × 10 ³	TOTAL NO. OF NAUPLII × 10 ³	HATCHERY RATE
			Male	Female	Collected	Maturation Rate (%)	Spawned	Spawning Rate			
None Selected	Squid	3	130	120	36	30%	28	77.8	6,214	2,182	35.1%
Selected	Squid	3	120	120	76	63.3%	76	100	15,416	8,620	55.9%

Table 2. Comparison of selected and non-selected P. monodon broodstock on maturation, spawning and hatching rate.

TREATMENT	FEED	NO. OF RUN	TOTAL STOCK			SPAWNERS			TOTAL NO. OF EGGS × 10 ³	TOTAL NO. OF NAUPLII × 10 ³	HATCHERY RATE
			Male	Female	Collected	Maturation Rate (%)	Spawned	Spawning Rate			
Selected Wild	Squid	2	180	80	54	67.5	50	92.6	9,015	5,720	59.5%
Pond Source	Squid	2	80	80	Collected 12 spawners, the gonads regress in the spawning tank.						

Table 3. Comparison of selective (wild) and pond reared P. monodon broodstock on maturation spawning and hatchery tank.

TREATMENT	FEED	NO. OF RUN	TOTAL STOCK			SPAWNERS			TOTAL NO. OF EGGS × 10 ³	TOTAL NO. OF NAUPLII × 10 ³	HATCHERY RATE
			Male	Female	Collected	Maturation Rate (%)	Spawned	Spawning Rate			
A	Squid	2	80	80	52	65%	48	92.3	8,762	4,810	54.9
B	Oyster	2	80	80	66	82.5%	66	100%	14,926	12,112	81.2

Table 4. Comparison of selected wild broodstocks feed with squid and oyster on the maturation, spawning and hatchery rate.

The design of the broodstock-hatchery-nursery complex of the center has combined the beneficial characteristics of both the above system but taking into consideration the limitation of spawner supply to ensure its economic efficiency. The smaller tanks could be effectively utilized if the nauplii production is less than 0.5 million using the small tank technique in hatchery management. But if the nauplii production is exceeding 0.5 million, the outdoor 40-ton tanks are used, hence adopting the large tank hatchery system. Thus, the design has the advantage of accommodating fluctuation of spawner supply and where the facilities do not pose a limiting factor in the target production.

The results of standardization of various larval rearing techniques and management of the nursery systems are being packaged for field testing. A manual on shrimp hatchery design, operation and management has been prepared for publication.

(b) Hatchery production performance and spawning season

Although the tiger shrimp (*P. monodon*) spawns all year round, many hatcheries have experienced erratic production levels. Good production and high survival rates are often achieved during March-June and September-December in the Philippines poor survival rate although the technique employed is essentially the same.

The production of post-larvae of the broodstock hatchery-nursery complex at Leganes Research Station also experienced the same situation with major production peak from April to June and a minor one in September to October. This phenomenon coincides with the spawning season of the tiger shrimps as reported by a Japanese research worker at the SEAFDEC Aquaculture Department, Dr. Motoh. The scientist recorded a major spawning peak in April-May and a minor peak in October-November at the coastal waters of Tigbauan (Table 5).

Month	P.monodon	P. indicus/merg.	Total
March		36,000	36,000
April	248,900	24,000	272,900
May	64,640	1,000	65,640
June	312,200	-	312,200
July	36,000	249,500	285,500
August	157,900	206,000	363,900
September	205,900	422,000	627,900
October	177,500	-	177,500
November	135,000	-	135,000
December	49,000	46,000	95,000
		TOTAL	= 2,371,540

Table 5- Monthly production record of shrimp juveniles
(p₃₅) IPPRP hatchery / nursery complex, Leganes Station

Hatchery experience indicates that it is important to time shrimp larvae production with the spawning seasons to ensure procurement of good quality spawners and ensure attainment of production targets (Figure 10).

(c) Use of Acetes as the prime food for rearing of tiger shrimp larvae

There are increasing attempts to rear shrimp larvae with artificial diet. Though various artificial diets have been formulated, they are too expensive and commercial application is limited. On the other hand, natural foods are difficult to maintain and often inconsistent in supply. This paper attempts to present the research effort to develop a suitable diet for shrimp larvae using locally available materials so that shrimp hatchery can be dispensed of a phycology laboratory and remove the full dependency on Artemia. Fresh and dry Acetes tissue have been selected for the experiments as Acetes are relatively cheap and available in large quantity. Several runs of larval rearing with finely ground tissues in different seasons and hatchery systems were completed. The results show that in dry season, the larvae in outdoor tanks fed with dry Acetes have the highest survival rate (68%) compared to the larvae fed with Chaetoceros (48%) or fresh Acetes (39%). The larvae in outdoor tanks molt to post-larval stages within 8-9 days. In contrast, the results from indoor hatchery show that the larvae reared with Chaetoceros had higher survival rate (52%) than those fed with Acetes (35%) and fresh Acetes (24%) however, the molting period from eggs to post larvae took 11–12 days. In rainy months, the survival of larvae reared with Skeletonema, dry and fresh Acetes in outdoor tank was 72%, and 52% and 38% and indoor tank 62%, 40% and 23% respectively. However, the molting period from eggs to post larvae was 9–10 days and 12–13 days in outdoor and indoor tank respectively (Table 7).

An illustration in histograms of the aforementioned results is shown in Figure 11.

(d) Experiments of feeding regime of postlarvae (PL₅-PL₃₅)

The 16 experimental earthen ponds which are designed for shrimp culture are being utilized for various experiments in order to yield the necessary information pertaining to the optimum stocking rates, economical feeds, feeding etc.

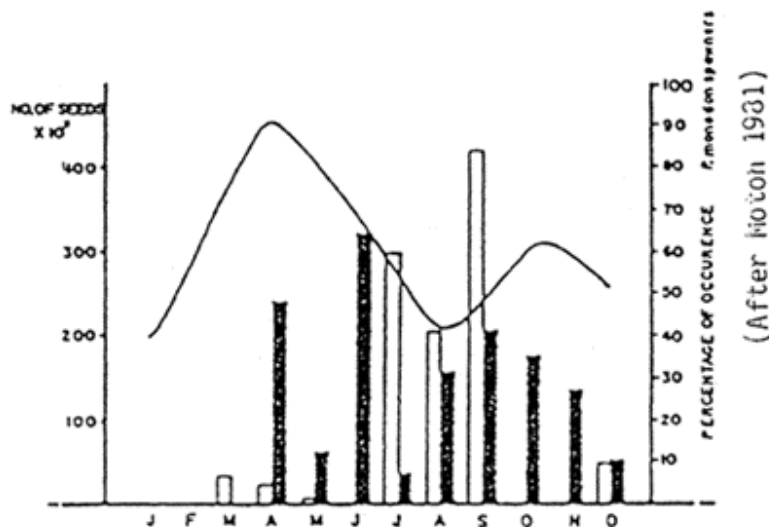

Fig. 10 -Relationship of shrimp seed production in hatchery and seasonal occurrence of spawners.

SEASON	HATCHERY	TREATMENT	No. of Run	AVERAGE AMOUNT OF ANIMAL/RUN				MOLTING PERIOD	SURVIVAL RATE N-PL ₁
				NAUDLI	PROTOZOEAE	MYSIS	PL ₁		
DRY	OUTDOOR	<u>A</u>	4	52,000	46,000	38,000	35,000	9	68%
		<u>B</u>	4	52,000	41,000	30,000	25,000	9	48%
		<u>C</u>	4	52,000	41,000	29,700	19,500	9	38%
	INDOOR	<u>A</u>	4	82,000	62,000	35,000	28,700	11-12	35%
		<u>B</u>	4	82,000	64,000	48,000	42,700	11-12	52%
		<u>C</u>	4	80,000	62,000	32,000	20,000	11-12	24%
RAINY	OUTDOOR	<u>D</u>	3	62,000	54,000	48,000	45,000	9-10	72%
		<u>A</u>	3	62,000	53,000	42,000	32,500	9-10	52%
		<u>C</u>	3	62,000	52,000	38,000	23,500	9-10	38%
	INDOOR	<u>D</u>	3	120,000	92,000	82,000	74,500	12-13	62%
		<u>A</u>	3	120,000	92,000	68,000	48,000	12-13	40%
		<u>C</u>	3	120,000	86,000	32,000	27,600	12-13	23%

TREATMENT A DRY ACETES
B CHAETOCEROS SP

C FRESH ACETES
 D SKELETONEMA SP

Table 6. The comparison of feeding scheme in different hatchery system and seasonal.

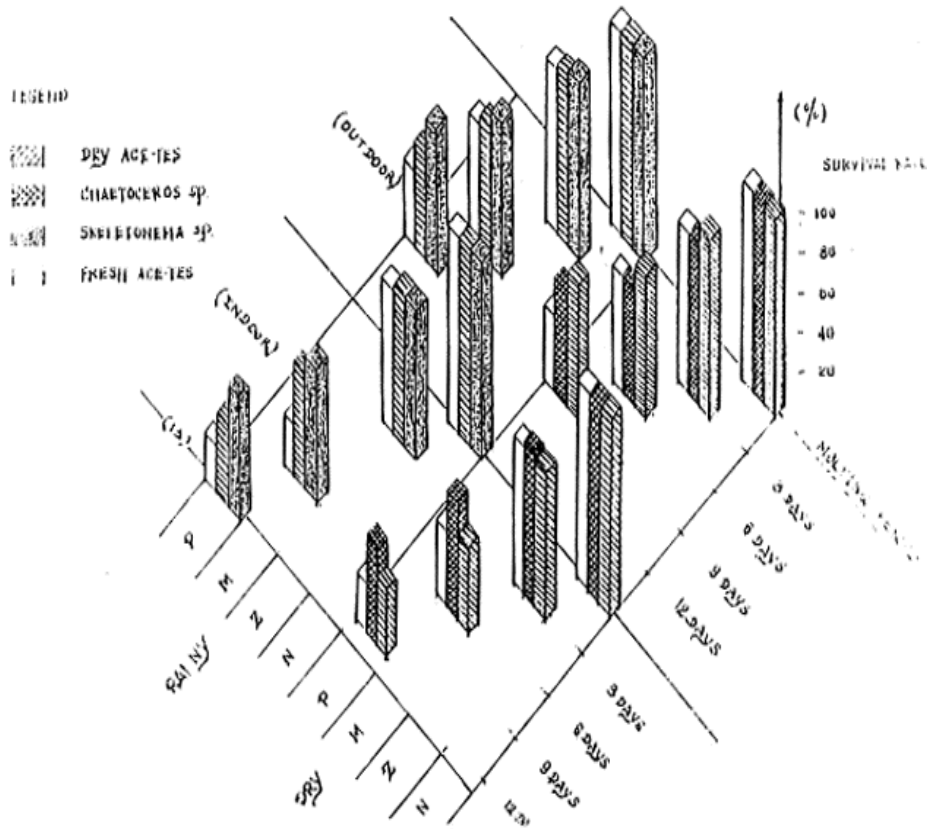

Figure 11. The histogram show the survival rate, and molting period in different feeding scheme, season and hatchery

Experiments were conducted to test the preference of postlarval shrimps (PL₅-PL₃₅) to fresh mussel meat and pellet feed. Results so far indicated that there is no significant difference in growth and survival rate between mussel meat and a commercial feed (40% protein content).

Since commercial feed is readily available and cheaper than mussel meat, experiments were further conducted to verify its economic efficiency and yield. The survival rate of the juveniles was found to be 33.4%. The length and weight of the juveniles were 45.65mm and 0.834 grams, respectively.

3.3.3.3 Natural food

(a) Marine yeast culture

Marine yeast culture is a micro-organism, whose size ranges from 2–12 micron. It can be used as the direct or supplementary feed for protozoa stage, and so far the best feed for Brachionus culture. Marine yeast used at the hatchery and nursery complex of RLCP were isolated from gonad of sea urchin. The medium used for mass produce of marine yeast were 30 gm of brown sugar, 3 gm ammonium sulfate and 1 gm of potassium phosphate in 1 liter of sea water. Marine yeast can be propagated as high density as 500 million per ml at pH 2.5-4 and salinity 30 ppt.

(b) Brachionus culture in circulation system

The rotifer Brachionus plicatilis is one of the most important zooplankton species primarily utilizes as live food in the larviculture of commercially important species of marine finfish and crustaceans. The studies were aimed to establish the technique for consistent mass production and sufficiency of the animal (Mysis stage of shrimp and 1st week of marine finfish).

For culture tanks, 1–3 tons of fiberglass tanks were usually used. The tank was installed with small filter tank and equipped with airlift system (Figure 11). Initially, the tank was disinfected after which filtered seawater, 75% and freshwater, 25% are introduced to about 2/3 of the tank volume. Chlorella is then added at a density of 2×10^5 cell/ml. The rotifer at 30–50 ind/ml was inoculated. The rotifer was usually cultured outdoor where temperature range is from 28–31°C. Airlift was operated throughout the culture period. Marine yeast (5×10^6) was added in the second day of culture twice daily in the amount of 1 liter per feeding. The population of Brachionus will increase to 500–700 cell/ml within 4–5 days.

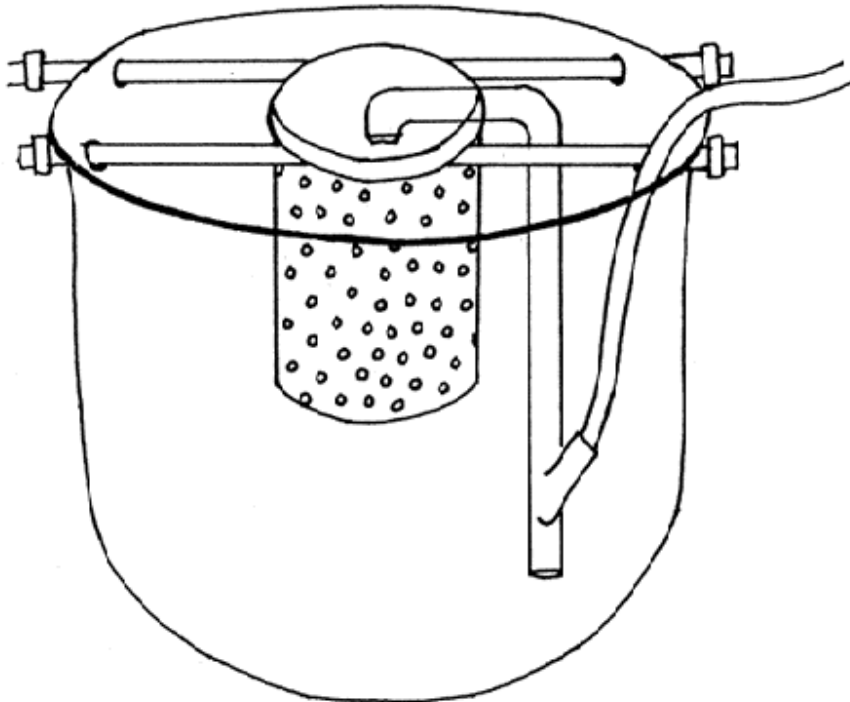

Figure 12. Design of rotifer culture tank.

3.3.3.4 Grow out

(a) Experiments on stocking density

To maximize output, an optimal level of stocking has to be determined. An experiment was conducted in 600 m² experimental ponds with juveniles stocking at 4, 8 and 12/m². Prior to stocking, the ponds were prepared by eliminating the predators and competitors before application of limes and fertilizers. About 30% of the water is replenished daily. The shrimps were fed with commercial pellets at 3–10% of biomass per day. The average yield ranged from 67.6 gm/m² to 73.8 gm/m². Although the net yields were not significantly different, the size of shrimps were highly variable. The stocking of 11 grams while the stocking rate of 4/m² yielded marketable size of shrimps of 25 grams in 90% of its harvest (Table 7) (Figure 13).

The growth performance is also demonstrated in the graph indicating that the best growth performance is at a stocking rate of 4/m². Although the over-all yield is high in higher stocking rate, the size range at 12/m² and 8/m² is not comparable with that at 4/m². It is apparent that the optimal stocking rate is 4/m².

Another experiment was conducted to determine whether stocking density could be increased through application of selective harvesting. Selective harvest was scheduled every spring tide beginning after the third months of culture. Pond filter nets were used for harvesting shrimps with more than 30 grams in weight. The remaining were harvested at the end of the experiment.

The result of the experiment is shown in Table 10.

(b) Evaluation of commercially available feed

The experiment was conducted in fifteen 500 m² brackishwater ponds to determine the response of *Penaeus monodon* juveniles fed with various artificial diets. Five treatments with three replicates each were: two commercial feeds containing 45% and 40% crude protein (treatments I & II), two experimental diets formulated to contain 35% crude protein (treatments III & IV) and non-fed, without artificial diet (treatment V). Shrimp were fed twice daily at feeding rate based on shrimp consumption.

Stocking rate per m ²	Mean survival rate (%)	Mean weight (gm)	Production	
			kg/600m ² /crop	kg/ha/crop
4	84	21.8	43.5	725
8	70	13.6	45.6	761
12	79	9.5	51.3	855

Table 7 - Average body weight, Survival rate and Production in different stocking density of P. monodon.

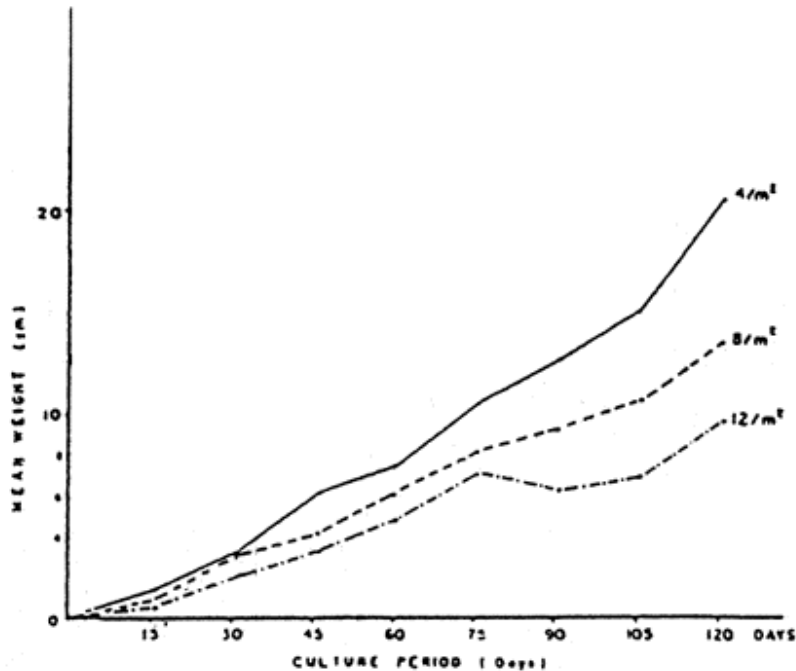

Fig. 13 -Growth Rate of P. monodon culture in ponds at different stocking densities.

Highest harvest mean weight was attained in treatment I (23.47 g) > III (19.25 g) > II (18.86 g) > IV (13.29 g) > V (9.27 g). Statistical analysis showed that differences in growth were significant at 5% level. However, growth in treatments I, II & III are comparable, also growth for treatments II, III & IV but significantly different from treatment V.

Highest mean survival was attained in treatment III (91.82%) > I (88.93%) > II (86.95%) > IV (83.62%) > V (82.62%). Statistical analysis showed no significant differences among treatments at 5% probability level.

Projecting on a hectare basis, mean yield for each treatment were: I (628.37) > II (496.35 kg) > III (485.35 kg) per crop in 120 days culture. Good yield was attributed to: provision of formulated feeds, use of pumps in addition to tidal changes for water exchange and control of predators, and pest eradication through proper pond preparation.

(c) Manipulation of extensive culture techniques for economic production of tiger shrimp (P. monodon) in brackishwater pond

Traditional shrimp farming is characterized by low yield ranging from 100 to 300 kg/ha/yr. It is therefore necessary to provide the fish farmer with appropriate technology that will immediately improve their pond yield with the

minimum investment. Experiments were conducted in two phases in nine 300-square meters brackishwater earthen ponds. The first phase was to evaluate the optimum stocking density without transfer of stock during the culture period up to harvest time. In the second phase, the best stocking density in the first phase was selected for trial. In this experiment, there were three treatments. In the first treatment, the stock was transferred every 45 days of culture while in the second treatment, the stock was transferred after 60 days of culture and the third treatment served as control with no transfer at all. All the stocks were transferred to newly prepared ponds.

Conventional methods for ponds preparation and liming were employed to condition the ponds as well as the elimination of undesirable organisms specifically predators. Organic and inorganic fertilizers were applied to initiate growth of natural food in both phases of the experiment. In the first phase experiment, the ponds were stocked with hatchery-bred fry obtained from the station at the stocking rates of 1, 2 and 4 individual per square meter with no supplementary feeding for the first two months of culture. Feed was introduced after the second months of culture at 6% body weight for the third month and at 4% body weight on the fourth month. The yields in 4 months of culture were 171 kg, 317 kg and 382 kg/ha/crop and with survival rates of 85%, 83% and 74, respectively (Table 8).

The stocking density of 2 per square meter was selected for the second phase experiment since more than 80% of the stock attained marketable size (25 g) while at 4 per square meter stocking rate, more than 60% of the stock were less than 15 g. Pond preparation essentially was the same as in the first phase and the resulting yield in the first treatment (45 days) was 422 kg/ha/crop, 525 kg/ha/crop in the second treatment (60 days) while the control showed yield of 372 kg/ ha/crop (Table 9).

(d) Alternate culture of P. monodon and P. indicus/merguiensis

Shrimp farmers have always experienced poor growth rate of P. monodon during the summer season or in ponds with high salinity. The production per unit area can be raised if species such as P. indicus/merguiensis which are tolerant to high salinity can be cultured as an alternate species for P. monodon during the dry season.

Experiments are being conducted to verify the economic viability using alternate species for dry and wet seasons so as to ensure continuous growth and have higher pond yield. Results of experiments are shown in Table 12.

(e) Intensive culture

The experiment was conducted in a 200 ml earthen pond with concrete dikes. Each pond was equipped with separated water inlet and outlet system; airlift for aeration purposes was operated throughout the experimental period. Pond was stocked with PL₂₁ from hatchery at the stocking density of 4, 8, 12 and 16 per square meter. Each stocking density was allocated at complete random designed with three replication. Prior to stocking, the pond was prepared by

eliminating the predators and competitors before application of limes. Commercial pellet (protein content 35–40%) were fed four times a day at 7:00 A.M., 1:00 P.M., 5:00 P.M. and 10:00 P.M. at the rate of 10%, 8%, 6% and 4% at the 1st, 2nd, 3rd and 4th months of culture respectively.

The experiment is still going on and is expected to harvest on early January.

STOCKING DENSITY	% SURVIVAL	AVERAGE BODY WEIGHT	AVERAGE PRODUCTION PER HECTARE
1/m ²	83.7	24.70	171 kilograms
	79.0	20.25	
	91.0	16.16	
2/m ²	85.0	19.22	317 kilograms
	74.0	17.48	
	90.0	20.02	
4/m ²	62.0	13.50	384 kilograms
	78.0	15.80	
	81.0	9.60	

Table 8- Data on average body weight, survival and average production per hectare of *P.monodon* at various stocking densities.

Table 9. Survival rate, average body weight and production per crop of *P. monodon* stock at 2/sq.m. in 300 sq.m. pond.

TREATMENT	TOTAL HARVEST kg	% SURVIVAL	AVERAGE BODY WEIGHT	AVERAGE PRODUCTION kg/ha/crop
<u>A</u>	13.8	72.5	31.7	460
	12.3	61.7	33.4	410
	11.9	67.3	29.7	396
Average	12.6	67.1	31.6	422
<u>B</u>	15	70.8	35.2	500
	17.3	90.5	31.8	576
	14.9	81	30.8	499
Average	15.7	80.8	32.6	525
	8.6	49.2	20.8	289

	8.6	49.2	20.8	289
	19.8	67.5	20.6	5260.3
Average	11.1	74.5	24.6	372

Treatment A - transferred after culture period of 45 days
Treatment B - Transferred after culture period of 60 days
Treatment C - No transfer

3.3.4 Research studies on farming of seabass and groupers

Amongst the brackishwater or marine finfish cultivated in the region, milkfish can be considered to be the most popular commodity providing substantial quantity of fish protein to the inhabitants of Indonesia., Taiwan and the Philippines. It has become increasingly important in Sri Lanka, Malaysia, Thailand and to a certain extent in the South Pacific Islands. While research studies on this species is certainly essential, research efforts have already been concentrated in the past decade with the financial support of IDRC. In recognizing the need to avoid duplication, RLCP has chosen the aquafarming of seabass and groupers as the next priority commodities deserving research attention in the region.

3.3.4.1 Background and research needs

Seabass (Lates calcarifer) and grouper (Epinephelus sp.) have been commercially cultivated in brackishwater ponds and marine cages, grow well if fed adequately and has wide acceptability. They are carnivorous species and therefore, their cultivation is dependent upon adequate supply of trash fish or compound feeds. It is also possible to culture them with forage fish such as tilapia. The seabass and grouper are relatively high priced species and therefore, very attractive for commercial or small-scale culture operations especially for rural economy in increasing the income of small farmers.

The seeds used for culture are usually obtained from the wild. However, the availability of fry in natural collecting grounds fluctuate widely from year to year making the supply very erratic. Seabass has been bred under captivity and hatchery procedures have been adopted from Thailand to supply large quantities of fry to fish growers. On the other hand, although grouper has been induced to breed under controlled conditions in Thailand, Singapore and Hong Kong, large scale production of fry has still been a technical problem. Research studies are needed to develop a dependable technology for the mass production of fry through induced spawning either by hormone injection or environmental manipulation. Although the larvae have been reared under experimental conditions, high mortality has still limited mass production of fry for reasons still to be determined. Despite the hatchery success of fry production in Thailand, the hatchery technology has yet to be perfected, refined and disseminated to other countries.

Brackishwater pond and cage culture of both species have been widely developed in Asia. However, the grow-out technology in terms of design of the ponds and cages, water management strategies, optimum stocking density and feeding are not yet standardized.

Existing culture practices still depend on trash fish as the main feeds which does not prove to be very efficient in terms of feed conversion efficiency. If used in large quantities, it may cause operational management problems by polluting the pond bottom. Moreover, the supply of trash fish are limited in many countries thus, becoming more expensive. Moist or dry, if formulated feed might be the best substitute, it can be economical to use local products as protein source.

In developing the hatchery and grow-out technology, the threat from infectious diseases must be overcome. The larval stages of finfish seem to be susceptible to infection by a variety of parasites, fungi and viruses which often resulted in high mortality. The culture system of carnivorous species such as grouper and sea bass in ponds or cages very much resemble the farming technology of poultry. But unlike other livestock, the technology of fish farming has not yet been fully developed such as appropriate artificial feeds, effective disease control, standardized operational management procedures and availability of cheap hatchery bred fry.

The research studies on finfish, are, therefore, geared towards filling up of technological gaps essential to the perfecting or standardization of operational management procedures. Hatchery production of fry farms is the main focus of current research efforts, although some research on grow-out cultivation are being conducted.

3.3.5 Research study

3.3.5.1 Mass production and larval rearing of seabass

While the broodstock of seabass were carefully nursed and developed as early as March 1982, first spawning of seabass in the Philippines was achieved in August 1983 by induced spawning using puberogen and HCG hormones. The dosage applied ranged from 100 IU-1000 IU for every kilogram of fish. To both male and female fish, two injections were administered at 24 hours interval between injection. After spawning, the eggs were collected using a dip net,, washed and placed in hatching containers or nursery tanks.

Brachionus were given as feed to the fish larvae 3 days after hatching when the mouth has fully developed. Artemia nauplii, adult Artemia and minced fresh fish were given at days 10, 20 and 30, respectively. The larvae at 40 days old were about 3–4 cm in size. The survival rates ranged from 6–12 percent (Figure 14).

After the preliminary success on seed production of seabass, experiments to standardize on mass production technology were being carried out. The broodfishes were conditioned in two 60-ton concrete tanks and induced to

spawn a number of times over the year by hormonal injection or environmental manipulation. Over 2 million of larvae in 1984 and 1 million larvae in 1985.

3.3.5.2 Seabass culture in brackishwater ponds

Seabass, Lates calcarifer Bloch, is one of the species of aquaculture importance in many Southeast Asian countries. It commands an excellent market price either sold live or freshly frozen. However, culture practice in most of these countries is very recent and as such, biotechnological problems remain to be solved. Seabass is carnivorous and present practice uses trash fish as feed. Alternative feed other than trash fish has to be tested since trash fish are not only expensive but that supply in the quantity needed is limited and in some cases not available in most of these countries.

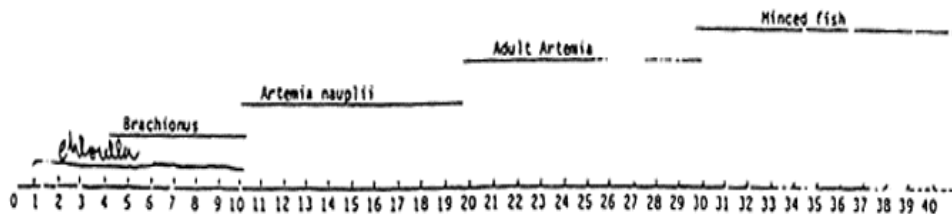

Figure 14 Feed and feeding scheme followed in the rearing of the sea bass larvae (L. calcarifer) at Leganes Research Station

Another major problem is the availability of seed for stocking. Wild-caught fry or fingerlings are very limited. Hence, seed production through hatchery is of prime importance to attain large scale production of marketable size seabss.

The research team of the SEAFDEC-NACA collaborative studies conducted at Leganes Research Station, SEAFDEC AQD have succeeded in spawning seabass and rearing the resultant larvae (NACA Newsletter, Vol. 2, No. 2, October 1983). The seed production procedure are now being refined.

Comparative study of hatchery-bred and wild-caught fry was conducted in brackishwater ponds fed with trash fish at the SEAFDEC Leganes Research Station in 1984. It was a 2x2 experimental design. The fish were stocked at 3 per sq.m. in 300 sq.m. earthen ponds with an average water depth of 80 cm. The result showed that hatchery-bred fry have comparable production with that of wild-caught fry (Table 10). Although the average initial stocking weight of the hatchery-bred fry was 5.0 g as compared to 40.44 g for the wild-caught fry, the growth rate is not significantly different as shown in Table 2. However, the average survival rate was 66.22% and 37.66% for wild-caught and hatchery-bred, respectively (Table 42). During the first 2 months of culture, it was noted that higher mortality occurred with the hatchery-bred fry. This is a very significant finding for it shows that ideal stocking size in ponds should be about 20–30 g.

3.3.5.3 First successful spawning of grouper, Epinephelus malabaricus, in the Philippines

The research team of SEAFDEC-NACA has succeeded in induced spawning and larval rearing of the grouper, Epinephelus malabaricus, at the SEAFDEC Leganes Research Station in Iloilo between October to December 1984.

Broodfish used in the experiment were maintained under ambient condition in 60 tons concrete tanks for one year. Of the total 36 females and 8 males grouper, 12 females and 6 males were selected for the experiment with 3 of the males fully matured. Size of the selected fish ranges from 3.6 to 6.5 kg for the female and 10 to 16 kg for the male.

Table 10. Comparison of growth rate of seabass (Lates calcarifer) culture in pond between wild fry and hatchery bred fry at stocking density of 3/m².

	Wild		Hatchery bred	
	B.L.	B.W.	B.L.	B.W.
Stocking	10.5 cm	40.44 g	5.2 cm	5 g
1st month	13.0	88.9	7.6	12.0
2nd month	16.4	204.2	10.6	26.02
3rd month	20.9	276.3	15.2	118.1
4th month	23.4	326.5	19.5	220.9
5th month	24.1	385.2	21.8	280.6
6th month	28.2	453.5	23.2	349.6

Table 11 Comparative Production of Hatchery-bred and Wild-caught Seabass Fry in 300 sq. m. Ponds at the SEAFDEC Leganes Research State, Iloilo.

POND NO.	FRY SOURCE	STOCKING DENSITY (pc/m ²)	TOTAL QUANTITY HARVESTED	QUANTITY (pcs.)	TOTAL BIOMASS (kg)	MEAN WEIGHT (g)	SURVIVAL RATE (%)	PRODUCTION PER HECTARE IN kg*
1	Wild caught	900	640		295.08	462	71.11	9,856
3		900	552		246.20	446	61.33	8,206
Average:		<u>900</u>	<u>596</u>		<u>270.94</u>	<u>454</u>	<u>66.22</u>	<u>9,031</u>
2	Hatchery-bred	900	326		124.53	382	36.22	4,151
4		900	352		111.94	318	39.11	3,731
Average:		<u>900</u>	<u>339</u>		<u>118.24</u>	<u>350</u>	<u>37.66</u>	<u>3,941</u>

* production data extrapolated from 300 sq. m. pond to one hectare in area.

Table 12 shows the different treatments, types of hormone and dosages used, as well as the time interval for injection and the result of the experiment. In treatment A, B and C, the fish were stripped 9 to 15 hours after the final injection was given. Dry method of fertilization was used in the three treatments. As for treatment D, the fish spawned naturally in the spawning tank after the last injection 12 hours later.

The poor rate of fertilization was attributed to lack of mature male fish. For treatments A, B and C, only two males were used while one male for 3 females fish was used in treatment D. Despite such problem, the experiment had demonstrated that grouper can be induced to spawning naturally in captivity as shown in treatment D.

3.3.5.4 Larval rearing

A larval rearing experiment was conducted using the hatchlings from the induced spawning experiment. These hatchlings were transferred from the incubator to the larval rearing tanks one day after hatch-out. The feeding scheme used in the experiment is shown in Figure 12.

Experimental result shows that newly hatched larvae fed with Isochrysis sp. mixed with sea urchin eggs gave a survival rate, see Table 3. Although the result is still preliminary, it appears that the use of minute organisms as feed may well serve as primary scheme for grouper larval rearing in the future.

Table 12 Induced Spawning of Epinephelus malabaricus using Different Hormones.

TREATMENT	FISH NUMBER	BODY WEIGHT (KG)	TIME INTERVAL (Hrs.)	NUMBER OF INJECTION	HORMONE USED	REMARK
A*	1	4.5	12	3	HCG 500 IU + 3 mg PG/kg of fish	Partial ovulation, 12 hours after final injection. No fertilization of eggs.
	2	3.6	12	3		Partial ovulation. No fertilization.

	3	5.2	12	3		Partial ovulation, 12 hours after final injection; fertilization rate 40%; hatching rate 20%. Larvae died after 6 days.
	4	4.8	12	2		Partial ovulation, 15 hours after final injection. Fertilization rate but no hatching.
	5	4.2	24	2	HCG 500 IU + 3 mg PG/kg of fish	Ovulation, 12 hours after final injection. Fertilization rate 60%; hatching rate 30%; larvae healthy.
B*	6	6.0	24	2		Partial ovulation. No fertilization.
	7	5.8	24	2		Ovulation, 15 hours after final injection. Fertilization rate 30%; hatching rate 60%; larvae died after 10 days

C*	8	4.1	12	3	LRH-a 10 ug/kg of fish	Partial ovulation, 15 hours after final injection. Fertilization rate 40%; hatching rate 50%; larvae healthy.
	9	4.5	12	3		Ovulation 12 hours after final injection. Fertilization rate 80%; hatching rate 40%; larvae healthy.
D**	10	5.2	24	2	1st injection - HCG 500 IU + 3 mg PG/kg of fish. 2nd injection - HCG 1000 IU + 3 mg PG/kg of fish.	All fish spawned naturally in spawning tank 12 hours after final injection. Fertilization rate 30%; hatching rate 70%; larvae very healthy.
	11	5.5	24	2		
	12	6.5	24	2		

* insufficient mature male

** used running male only with one injection given during the last injection for the female

Table 13 Survival rate of Epinephelus malabaricus Larvae.

TREATMENT	NO. FISH AT DAY 0	NO. FISH AT DAY 20	SURVIVAL RATE	REMARK
A	8,000	-	-	All larvae died after culture period of 6 days
B	20,000	-	-	All larvae died after

culture period of 10 days

C 15,000 1,350 9.0%

Figure 1. Feeding Scheme for Larval Rearing of Epinephelus malabaricus.

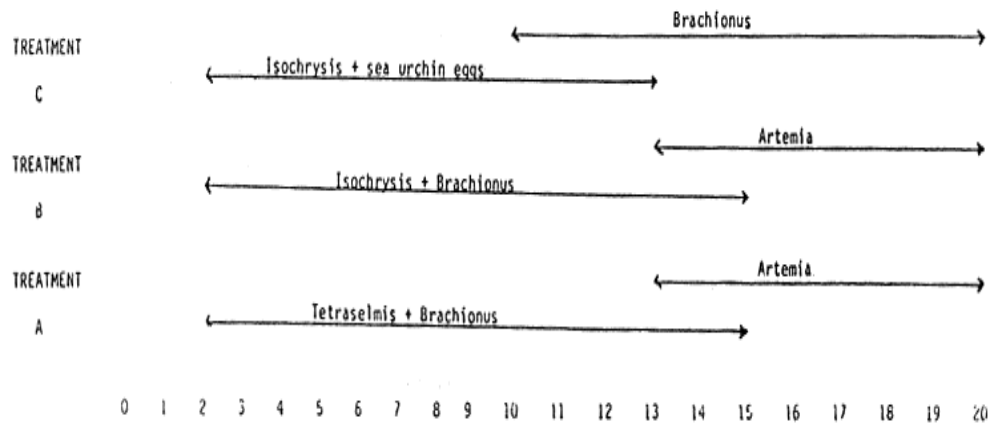

CONCLUSION AND RECOMMENDATION

Shrimp culture and development

The following constraints to shrimp culture development that has to be solved;

Spawner

Inadequate supply of wild spawners remains as one of the major constraints in the development of the shrimp farming industry notably the tiger shrimp (P. monodon). To ensure consistent supply of the spawners of this species, many hatcheries in Southeast Asian countries have been undertaken to develop the techniques for maturing P. monodon on captivity but so far results are not consistent. Thus, techniques for gonadal maturation of captured and pond reared adult tiger shrimps need to be improved.

Larval Feeds

Natural food still remains the major feed in shrimp larval rearing operation. One of the key factors ensuring success in shrimp hatchery production is the timely supply of the needed food organisms in sufficient quantity. Majority of the hatcheries usually have algal culture and zoo-plankton areas to maintain pure stocks of the needed live feeds such as Chaetoceros, Skeletonema, Tetraselmis, Chlorella and Brachionus. The algal stocks can be easily maintained in the standard culture media whereas, a pure rotifer stock must be sustained through culture year-round. However, contamination by undesirable species always occur as well as failure in diatom bloom especially during the rainy months resulting in insufficient food supply for the larvae. Maintenance is

not only costly but also rerequires a specialist for this purpose. On the other hand, big tank hatchery system utilizes natural diatom. The major problem encountered is the overbloom of diatoms some of which are undesirable species such as *Nitzschia* sp., which can not be easily eaten by the larvae and may normally attach to the appendages of larvae. This makes molting impossible and high mortality occurs particularly in outdoor hatcheries. Failure in diatom may also occur especially during raining season leading to lack of feed in the larval rearing tanks.

However, both private and government sectors have attempted to develop pelleted artificial feed or microencapsulated diet for larval rearing. It will be very advantageous for the shrimp hatchery industry if artificial larval feeds become reliable. However, supplemental live food is still needed.

Development of Compound Feeds

Usually, shrimps are fed with minced trash fish or mussel as well as fine bran. However, not all portions of the given feeds are consumed or that the given feeds may be in excess so that it pollutes the pond water. This leads to lower feed conversion efficiency. For intensive culture, the use of formulated diets is essential especially so that the supply of fresh feeds is limited if not costly. Despite the limited studies on the nutritional requirements of shrimps, several formulated diets have already been developed and commercially produced in some countries. Some of these feeds appear to have better conversion efficiency compared to fresh feeds. However, the prices may be high and supply is insufficient. Since the formulation of these diets are considered trade secrets, the manufacturers generally limit production to increase market demand especially if the diet shows good feed conversion efficiency. Thus, feed cost will then increase. As a result of these conditions, the development of intensive culture of shrimp is hampered.

To offset these problems, more research must be done on the nutritional requirements of shrimp as well as its physiology and biology in order to improve existing formulated diets or develop new ones. Suitable cheap feedstuff must be found and incorporated into the diets. Testing of these diets must be done not only on an experimental scale but also in small commercial scale to ascertain conversion efficiency. Once found to be efficient, production technique must be standardized, packaged and made freely available to any interested small or large scale manufacturing company for commercial production. This will minimize monopoly of feed supply and thus lower cost and increase its availability to shrimp farmers who would pave the way to intensive shrimp farming.

Diseases

Disease is a serious problem both in hatcheries and rearing ponds. The most serious diseases causing organism at larval stage are *Zoothamnium*, Fungi (*Lagenidium*) and bacteria (*Vibrio*) which may contaminate the intake water, or may result from a collapse of *Artemia* population in the pond. *Lagenidium* is found in the cyst form during the cold season in the ovary of wild spawners.

When the shrimp spawns, Lagenidium is excysted and develop very quickly. Then they attach to the larvae as early as nauplius stage causing heavy mortalities. Vibriosis mostly affects the shrimp during larval stage. Shrimp larvae show general signs of severe stress that include: increased opaqueness of abdominal muscle, expansion of chromatophores (usually appears reddish in color), and occasionally a dorsal flexure of the third abdominal segment.

It is very difficult and expensive to treat the infected larvae. The only way is to prevent the onset of fungal and bacterial infection. This can be done by separating spawning tank from the rearing tank and using clean or purified rearing tank.

In rearing ponds, black gill disease caused by Fusarium spp. also occurs when the bottom of the rearing pond is in bad condition. Body cramps has also been noted in pond reared P. monodon and P. japonicus when these were caught in daytime under the hot sun. High mortalities usually follow. Prevention is always better than cure. Intensive culture using high stocking densities should be avoided until effective treatment for the disease is found.

Technology Packaging

Although various techniques have been developed, existing techniques in shrimp farming as a result of more than 50 years of research studies have yet to be refined, standardized, packaged and tested in different environmental conditions into an appropriate technology that can be disseminated to the shrimp farmers. The techniques that has been established in one country may not be applicable to other countries. Hence, shrimp farming techniques are not disclosed and will remain untold until such time that aquaculturists/researchers are confident that the research results can be packaged into a standard technology.

Marine Finfish

1. Development of Compound Feed

Seabass (Lates calcarifer) and grouper (Epinephelus sp.) are carnivorous species and the existing culture practice is dependent upon adequate supply of trash fish. Due to the limited supply of trash fish in many countries, such as Philippines, the price of trash fish becomes more expensive. Excess of trash fish pollutes the pond water. To solve this problem, formulated diet should be introduced, more research must be done on the nutritional requirement of cultured species as well as physiology and biology in order to formulate the suitable compound feed to substitute trash fish.

2. Larval rearing

Despite hatchery success of fry production in many countries, hatchery technology especially on larval rearing has yet to be perfected, standardization and refinement of larval technique are needed.

The major constraint in the larval rearing of marine finfish is larval feed, especially for the larvae with small mouth size like grouper. The size of cultured Brachoinus are bigger than the mouth size larvae. Research should be aimed to find out the smaller size feed or develop pelleted artificial feed for larval rearing.

In addition, grouper larvae are very sensitive on handling, care should be taken even during cleaning of tank bottom or replenishment of water.

Disease

Disease is one of the serious problems on larval rearing. The most serious disease are fungi and bacteria. In addition, air bubble disease which may be caused by inflation of gas bladder of larvae always happen with seabass larvae. As a resolution to the problem, research on diseases should be given priority.
